

**SÉRIE: SAMONOSNÉ POSUVNÉ BRÁNY S**  
**SERIES: CANTILEVER GATE S**

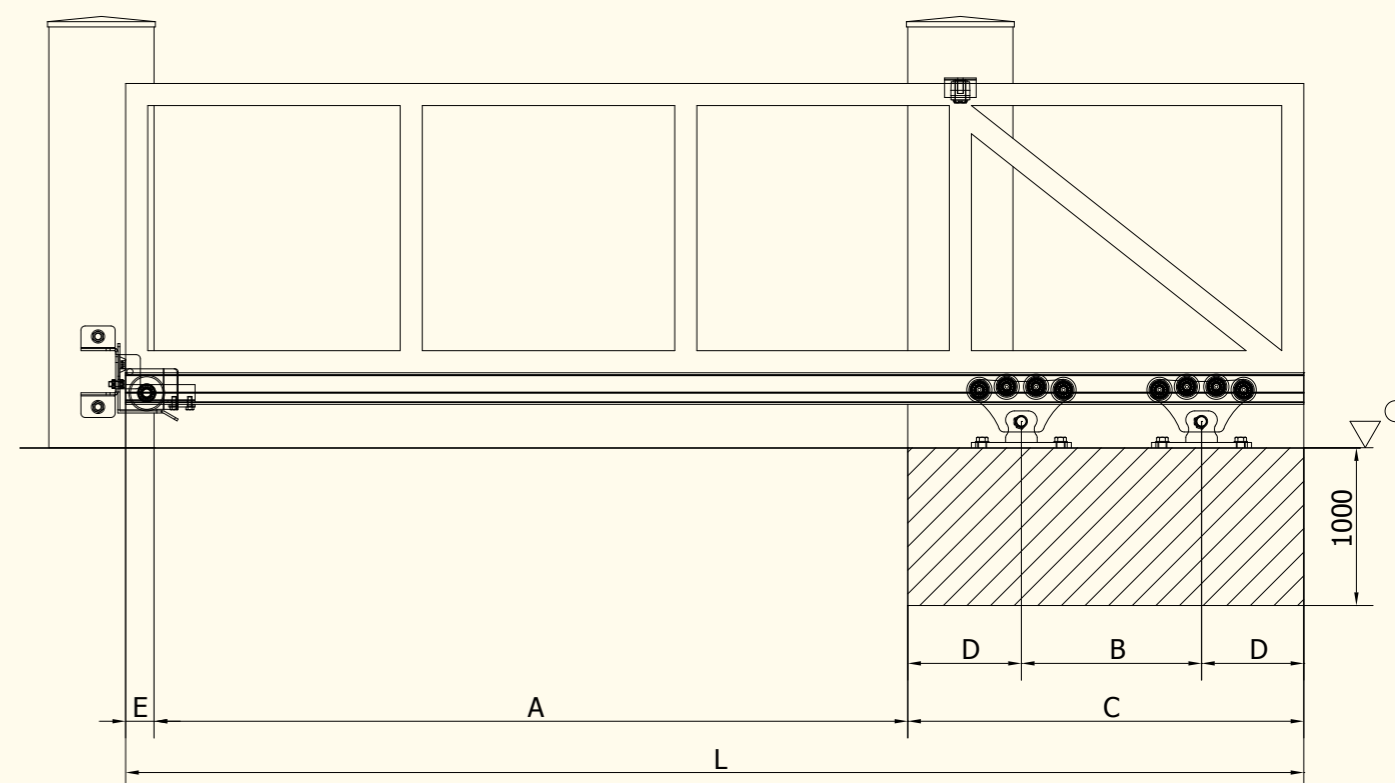

$$B = 0,3 \times A$$

$$L = A + B + (2 \times D) + E$$

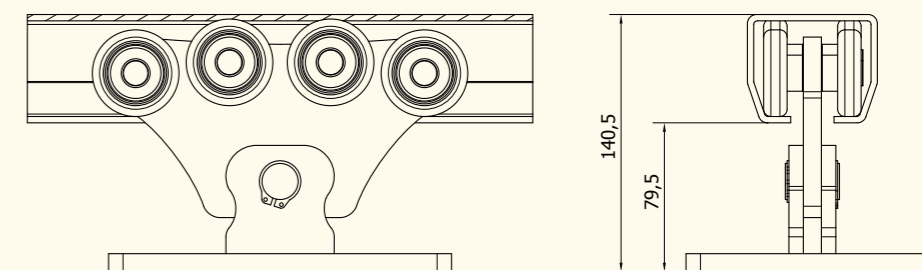
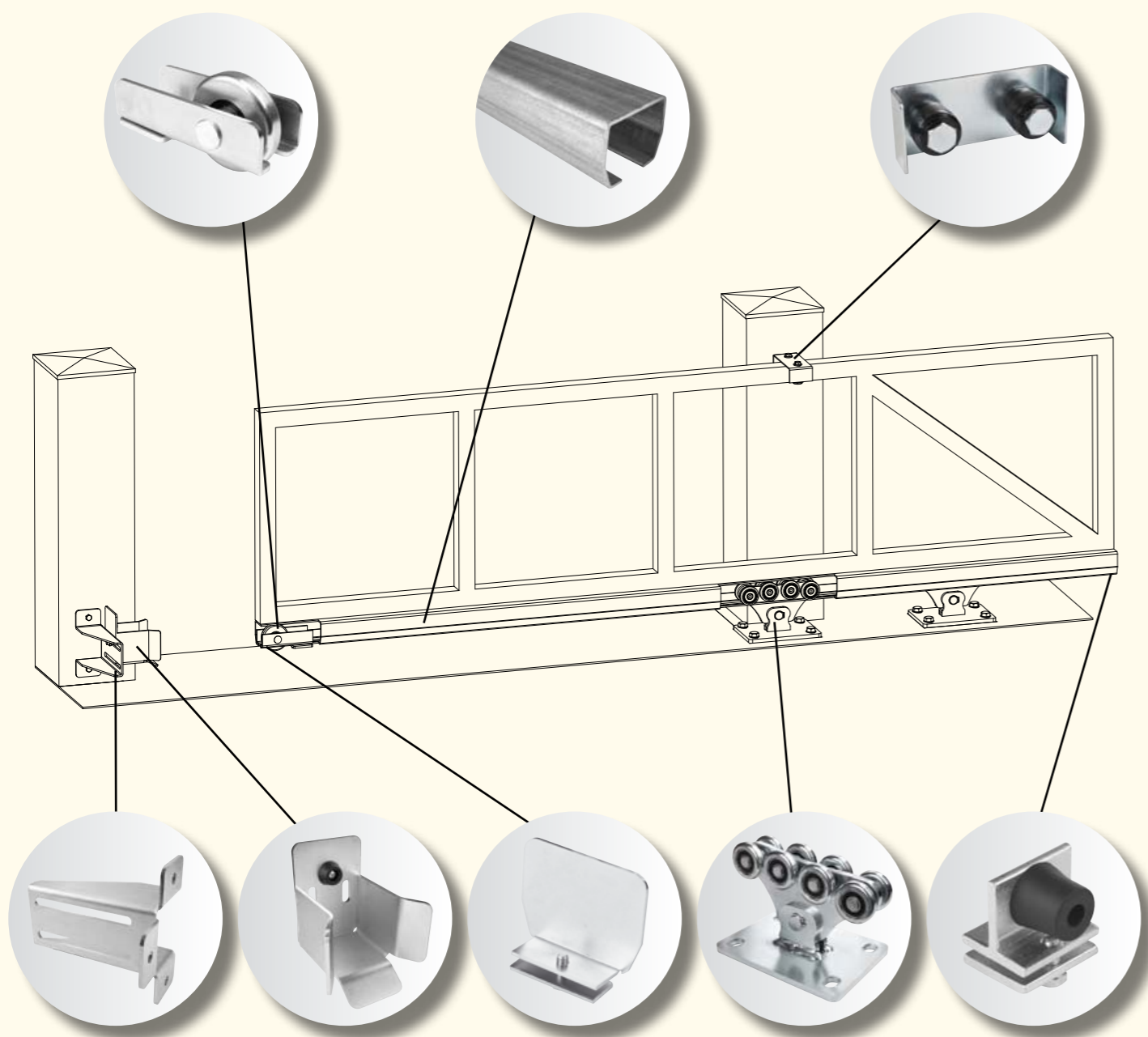

	mm; kg	mm; kg	mm; kg	mm; kg	mm; kg	mm; kg	mm; kg	mm; kg
<b>A</b>	3000	3200	3400	3600	3800	4000	4200	4500
<b>max.váha brány</b> <b>max.weight gate</b>	450 kg	425 kg	400 kg	375 kg	350 kg	325 kg	300 kg	270 kg
<b>B</b>	900	960	1020	1080	1140	1200	1260	1350
<b>C</b>	1400	1460	1520	1580	1640	1700	1760	1850
<b>D</b>	250	250	250	250	250	250	250	250

**VOZÍK OSMIKOLOVÝ PRO POSUVNOU SAMONOSNOU BRÁNU**  
**EIGHT WHEELED CARRIAGE FOR CANTILEVER GATE**

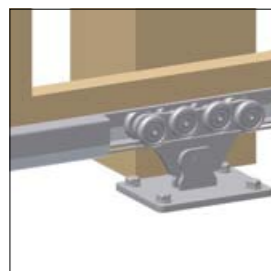
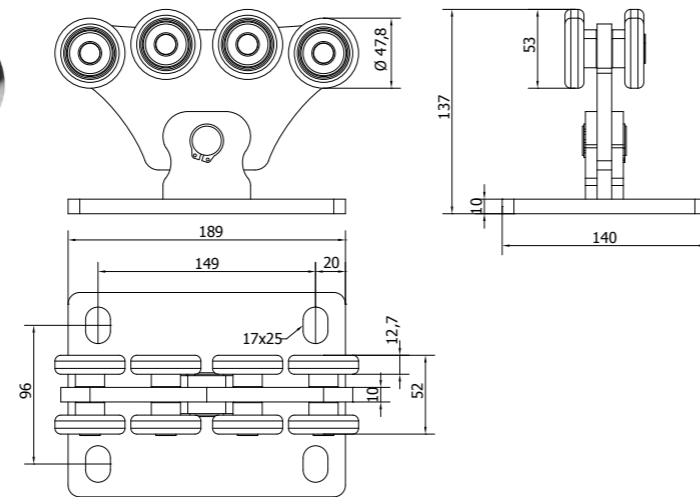

Art.	A	Šířka	1Pc		
	MAX mm		kg	pcs	kg
<b>SPEED S</b>	4500	STAGE SB/SZ	4,5	2	9

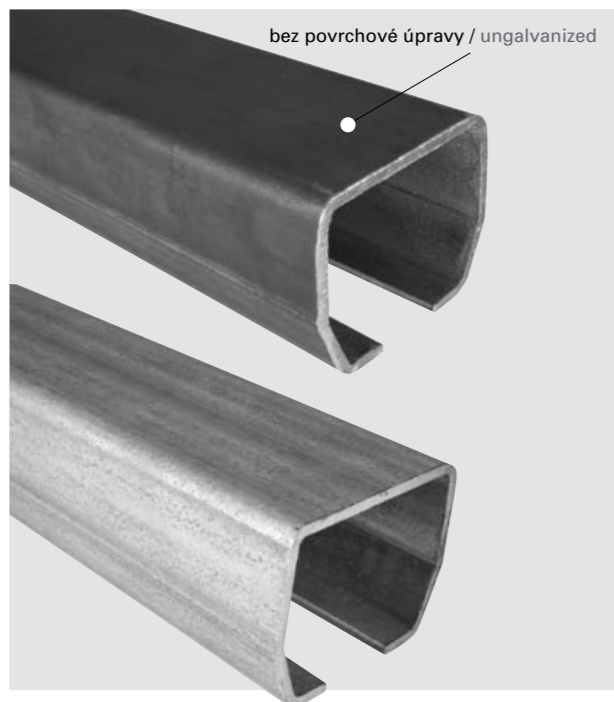

**ŠÍŘKA „C“ PROFIL PRO POSUVNOU SAMONOSNOU BRÁNU**  
**“C” PROFILE GUIDE FOR CANTILEVER GATE**

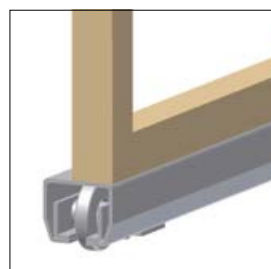
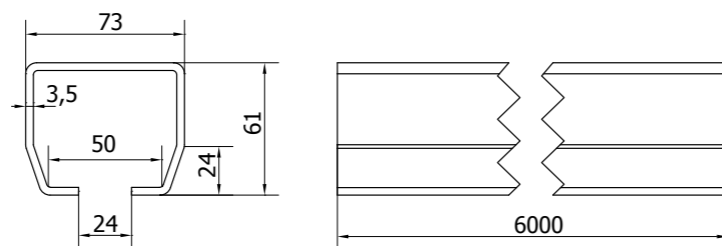

Art.	Vozík	Povrchová úprava	1m		
			kg	m	kg
<b>STAGE SB</b>	SPEED S	ČERNÁ / UNGALVANIZED	5,5	192	1056
<b>STAGE SZ</b>	SPEED S	POZINK	5,5	192	1056

**NÁBĚH S KLADKOU PRO POSUVNOU SAMONOSNOU BRÁNU**  
**GUIDE SUPPORT WHEEL FOR CANTILEVER GATE**

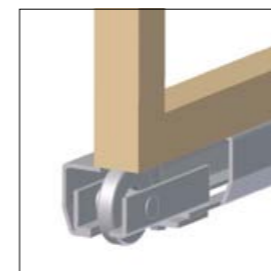
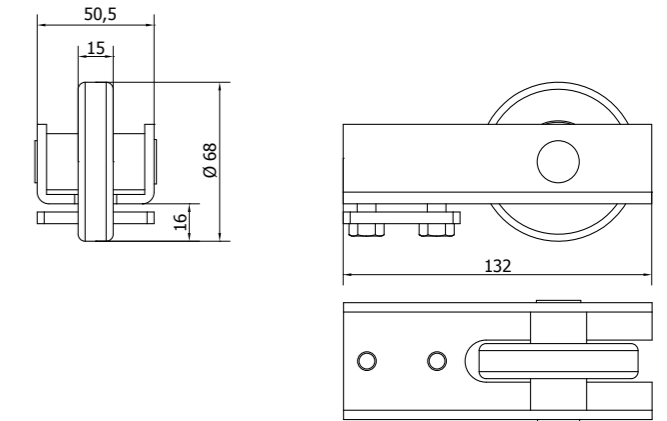

Art.	Šířka	1Pc		
		kg	pcs	kg
<b>RUN S</b>	STAGE SB/SZ	0,98	10	9,8



**DOJEZDOVÁ KAPSA SPODNÍ PRO POSUVNOU SAMONOSNOU BRÁNU**  
**END STOP FOR CANTILEVER GATE**

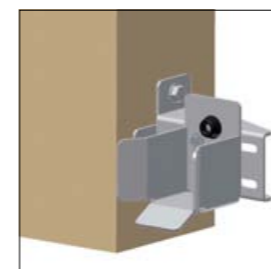
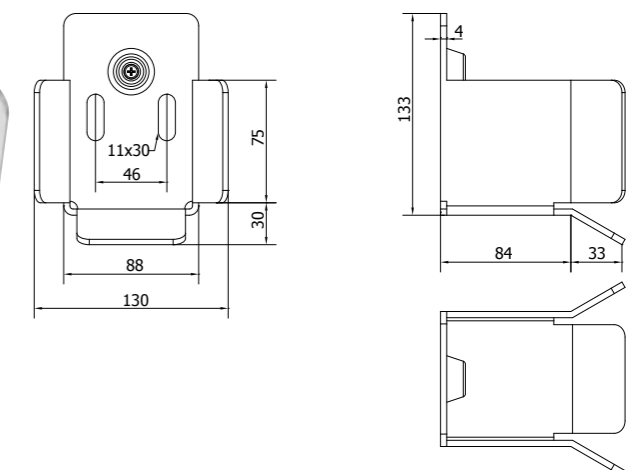

Art.	Šířka	1Pc		
		kg	pcs	kg
<b>LAST S</b>	STAGE SB/SZ	1,18	2	2,36

**KONZOLA PRO DOJEZDOVOU KAPSU**  
**END STOP BRACKET**

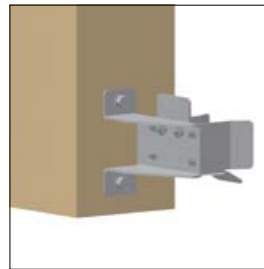
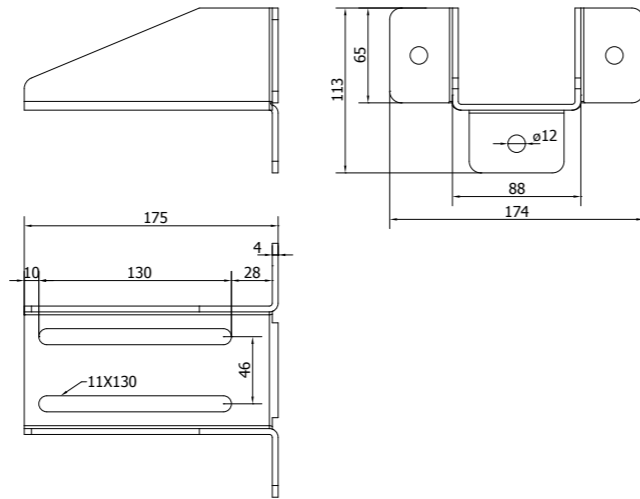

Art.	Doraz	1Pc		
		kg	pcs	kg
<b>PARK</b>	LAST S/M	1,14	2	2,28

**DORAZ VNITŘNÍ PRO ŠÍNU „ C “ PROFIL**  
**INTERNAL GUIDE END STOP**

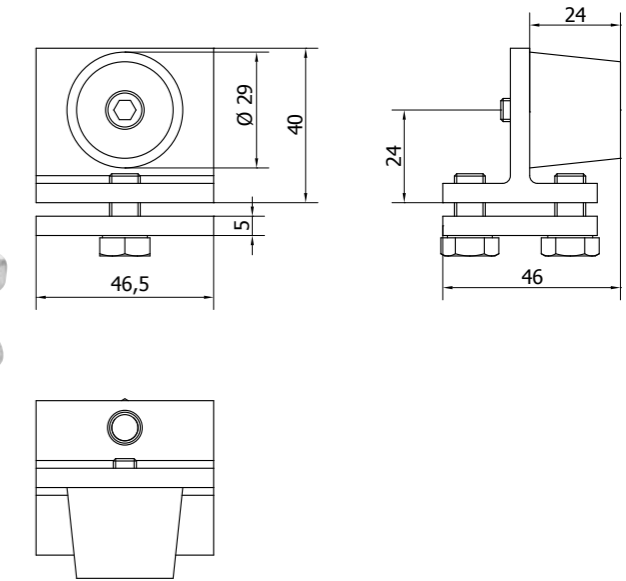
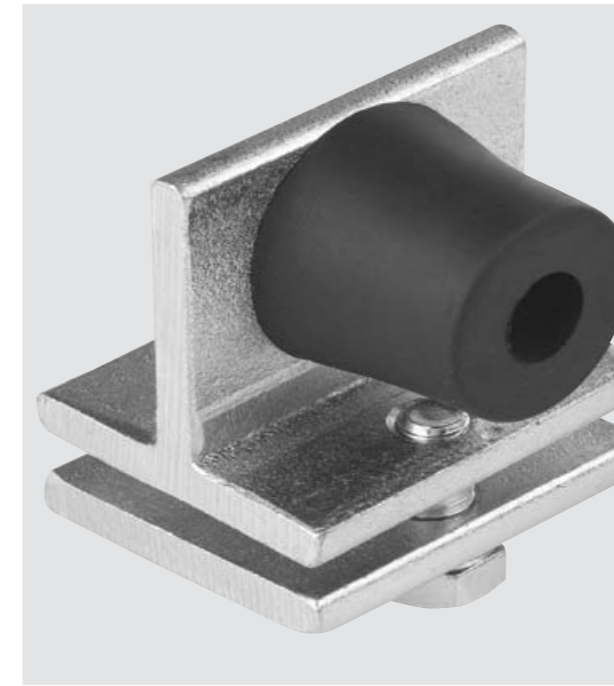

Art.	Šíma	1Pc		
		kg	pcs	kg
<b>FINISH S</b>	STAGE SB/SZ	0,24	20	4,8

**ZÁSLEPKA PRO ŠÍNU „ C “ PROFIL,**  
**NEZÁVISLÁ SE ŠROUBEM**  
**GUIDE END CAP WITH SCREW,**  
**INDEPENDENT**

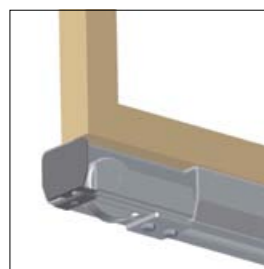
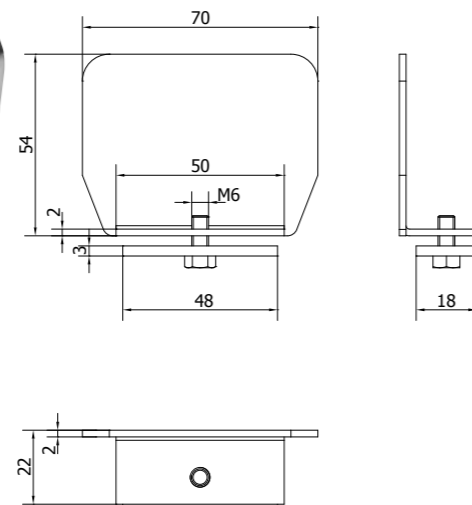

Art.	Šíma	1Pc		
		kg	pcs	kg
<b>PILOT SN</b>	STAGE SB/SZ	0,1	10	1